

4' I. D. manhole with flat top

Specifications:

Concrete: 5000 psi min., 5-6% air

Reinforcement:

Walls: 8x2x4 gauge WWF to equal .12 sq. in. / V. F. min.

Floor and top slab: #4 rebar @ 6" O. C. both ways

Conforms to ASTM C-478 and A. A. S. H. T. O.

HS-20 standards

Sealant: 1" ConSeal CS-101 mastic rope sealant on all joints

Weights (lbs.):

Monobases: 4' - 4870 3' - 4003 2' - 3136 Risers: 4' - 3469 3' - 2602 2' - 1764 1' - 867

Base Slab: 3596 Flat slab tops: approximately 2124 lbs.

Volumes (gal.):

Monobases: 4' - 329 3' - 235 2' - 141 Risers: 4' - 376 3' - 282 2' - 188 1' - 94

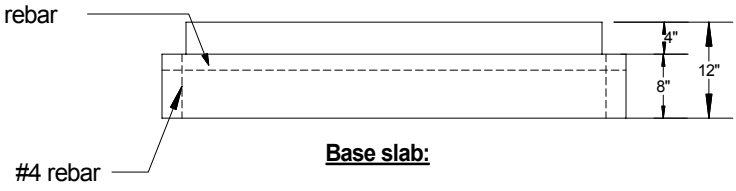

www.concretebuildingsupply.com

Concrete Building Supply Co.

Northeast Concrete Products, Inc.

(P) (518) 563-0700 (F) (518) 563-1392 1024 Military Turnpike, Plattsburgh, New York 12901

SCALE- 1/2" = 1' DRAWN BY- R. E. S.

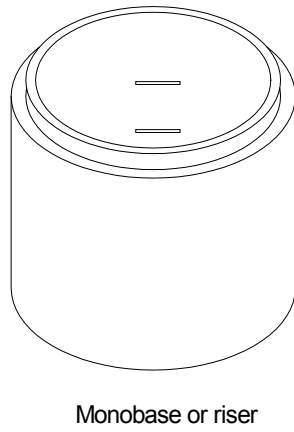
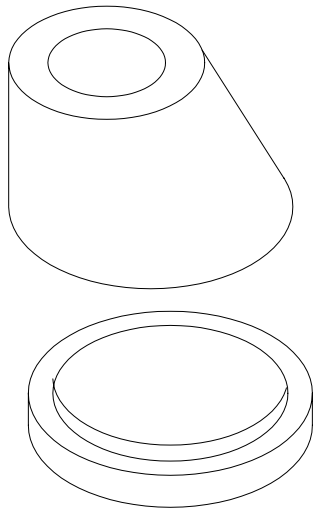

Monobase or riser

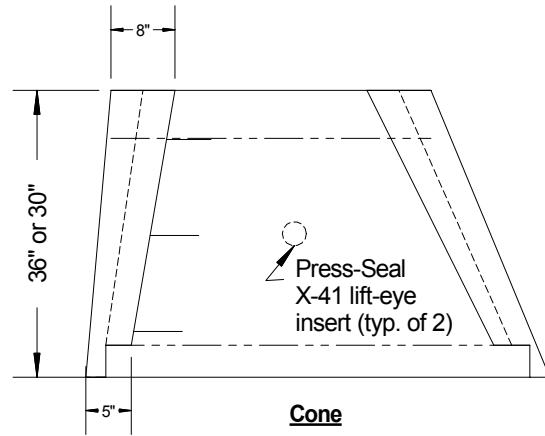

Cone

Isometric views - not to scale

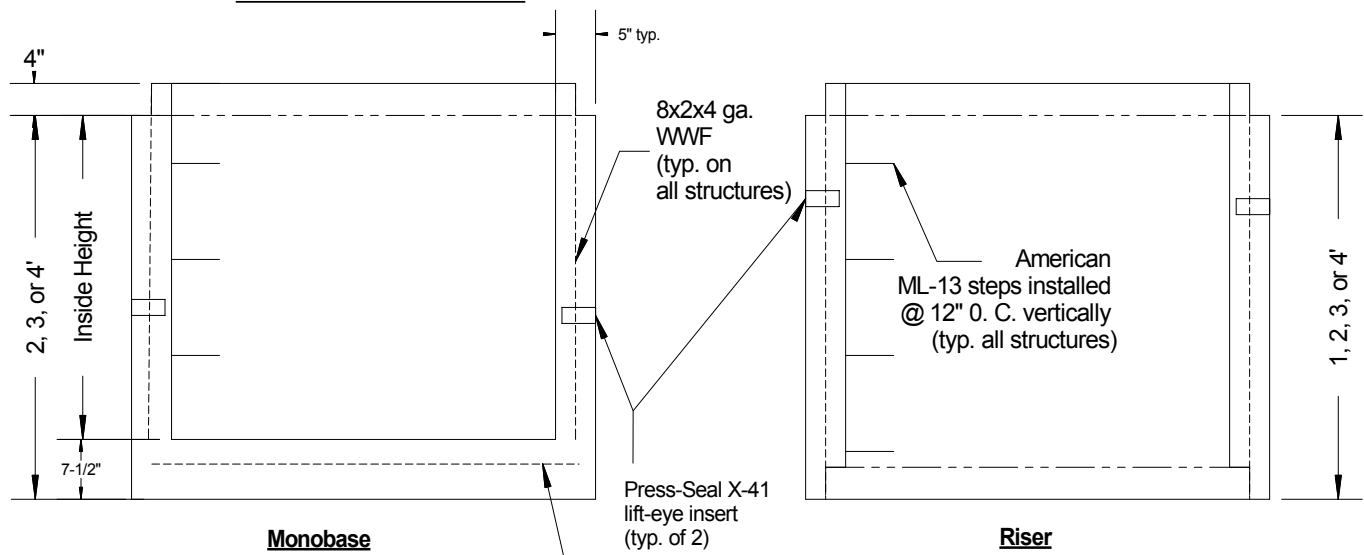

Monobase

Riser

4' I. D. manhole with cone

Specifications:

Concrete: 5000 psi min., 5-6% air

Reinforcement:

Walls: 8x2x4 gauge WWF to equal .12 sq. in. / V. F. min.

Floors: #4 rebar @ 6" O. C. both ways

Conforms to ASTM C-478 and A. A. S. H. T. O.

HS-20 standards

Sealant: 1" ConSeal CS-101 mastic rope sealant on all joints

Weights (lbs.):

Monobases: 4' - 4870 3' - 4003 2' - 3136 Risers: 4' - 3469 3' - 2602 2' - 1764 1' - 867

Base Slab: 3596 Cones: Tall - 3952 Short - 2964

Volumes (gal.):

Monobases: 4' - 329 3' - 235 2' - 141 Risers: 4' - 376 3' - 282 2' - 188 1' - 94

8x2x4 ga. WWF

#4 rebar

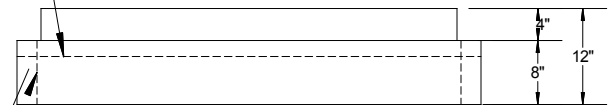

Base slab

www.concretebuildingsupply.com

Concrete Building Supply Co.

Northeast Concrete Products, Inc.

(P) (518) 563-0700 (F) (518) 563-1392 1024 Military Turnpike,
Plattsburgh, New York 12901

SCALE- 1/2" = 1'

DRAWN BY- R. E. S.

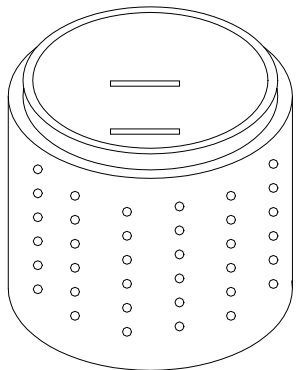

Perforated riser

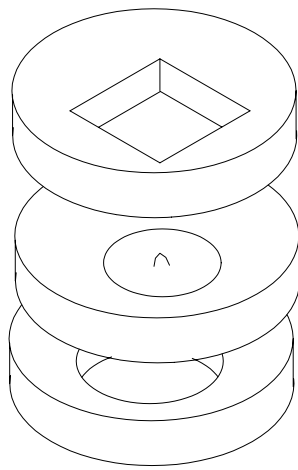

Isometric views - not to scale

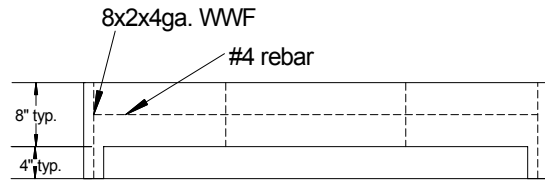
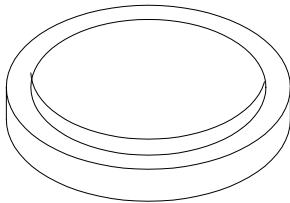

26" x 26" opening

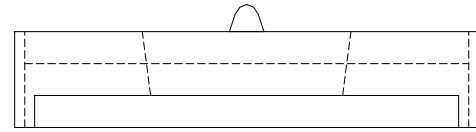

24" plug

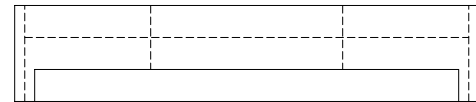

24" or 30" round opening

Flat slab tops

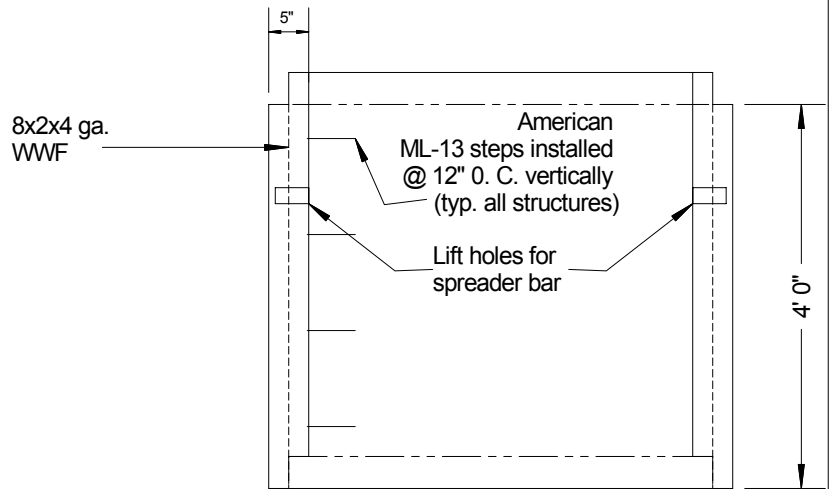

Riser

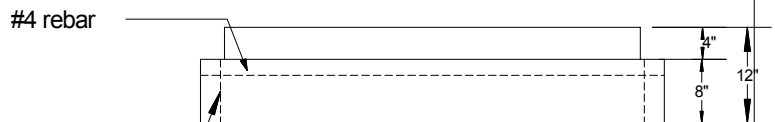

Base slab

4' I. D. perforated manhole

Specifications:

Concrete: 5000 psi min., 5-6% air

Reinforcement:

Walls: 8x2x4 gauge WWF to equal .12 sq. in. / V. F. min.

Floor and top slab: #4 rebar @ 6" O. C. both ways

Conforms to ASTM C-478 standards

Perforations are 2 1/4" in diameter

Sealant: 1" ConSeal CS-101 mastic rope sealant on all joints

Weight: Less than 3469 lbs.

www.concretebuildingsupply.com

Concrete Building Supply Co.

Northeast Concrete Products, Inc.

(P) (518) 563-0700 (F) (518) 563-1392 1024 Military Turnpike,
Plattsburgh, New York 12901

SCALE- 1/2" = 1'

DRAWN BY- R. E. S.